

## General

C2H4-LD is one of the smallest size Dual Channel Ethylene sensor module in the world. Its Persistent Stability and Temperature Effect Resistance are much favored in flammable and explosion hazard gas and consistent accuracy through the life cycle. C2H4-LF is flow-thru type, giving two holes letting tube can be used.

---

# ELT Sensor Data Sheet for C2H4-LD



## Features

- Non-Dispersive Infrared (NDIR) Dual Channel Technology to measure C2H4 levels.
- Excellent compensation of Temperature Effect on C2H4 concentration.
- Output : TTL-UART, I2C, ALARM, PWM or Analog Voltage is optional.
- Easy Calibration with Non-Periodic Manual Calibration (0\_MCDL : CAL1) and Periodic Automatic Calibration (0\_ACDL : CAL2).

• Size : 33mmx33mmx13.1mm

• Weight : 10 grams

Ver 1.1

## Specifications

### Applications

Gas leakage alarming detector or equipment of C2H4, Ripeness of Banana or other fruits, Residential Buildings, LNG or combustible gases in Mine, metallurgy, liquefied gas station, petroleum, fuel gas ,etc.

### General Performance

**Operating Temperature :** -20 ~ 50°C

**Operating Humidity :** 0 ~ 95% RH (Non-condensing), 'G : 0 ~ 99% RH (Non-condensing) <sup>(1)</sup>

**Storage Temperature :** -30°C ~70°C

### Measurement

**Sensing Method :** NDIR (Non-dispersive Infrared)

**Measurement Range :** 0~5,000ppm

Option: 0~27,000(= 0 ~ 100% LEL)

**Accuracy :** ±3% of F.S. <sup>(1),(2),(3),(4)</sup>

**Resolution:** 0.05% (= 1% LEL)

**Zero Repetition :** ±1% of F.S. @25°C, **Span Repetition :** ±2% of F.S. @25°C

**Lowest Detection Limit:** 1% of F.S. @25°C ( 100ppm)

**Step Response Time (90%, 1/e) :** 30 seconds / 20 seconds

**Sampling Interval:** 3 seconds

**Warming-up Time :** < 6 seconds (for Detection), 2 minutes (for Accuracy)

### Electrical Data

**Power Input :** 5V ± 5% (5)

**Current Consumption :** Normal mode : 22mA, Peak : 360mA, Sleep < 0.5mA

### Product Derivatives and Relative Functions

Products	Feature	3.3V Option
C2H4-LD-G	Enable sensor to operate in very humid environment up to 99 %RH humidity, protecting PCB from rustiness.	C2H4-LD-G-3V
C2H4-LF	Flow-thru type of C2H4-LD, open two holes on side and disable the white colored filter on the top of Gold Cavity.	C2H4-LF-3V
C2H4-LF-G	Enable sensor to operate in very humid environment up to 99 %RH humidity, protecting PCB from rustiness.	C2H4-LF-G-3V

(1) C2H4-LD-G: 0 ~ 99% RH (Non-condensing) for Industrial Application of Ethylene gas.

(2) 2% should be added for absolute measurements for uncertainty of calibration gas mixture unless '0' ppm or '0'ppm standard gas calibration is done.

(3) Air pressure is assumed as 101.3 kPa.

(4) If sensor is affected by the shock, may need field calibration before installation.

(5) DC Supply should be regulated without ripple < 100mV, low noise power source is needed for best accuracy.

C2H4-LD has various output TTL-UART, I2C while as Analog voltage is selectable as option.

**Pin Map with J11&J12 Connectors**

J-11	Description	
1/3	V <sub>DD</sub> (+5VDC)	
2/4	GND	

J-12	C2H4-LD	C2H4-LD (Analog Voltage Option)
1	TTL RXD (← CPU of Master Board )	
2	TTL TXD (→ CPU of Master Board)	
3	I2C SCL	
4	I2C SDA	
5	GND	
6	Reserved	Analog Voltage Output (0.5~4.5V)
7	CAL2-pin : 0_ACDL (for every 7 days ACDL with periodic CO2-'0'ppm circumstance)	
8	Reserved	
9	CAL1-pin : 0_MCDL (for 2 minutes MCDL with C2H4-'0'ppm- N2-based-gas or Fresh Air)	
10	Reset (Low Active)	

**UART** 38,400BPS, 8bit, No parity, 1 stop bit  
 9,600 or 19,200 BPS can selectable through command sets or EK-100SL.

**I2C** Slave mode only, Internal pull up resistor 10kΩ  
 TTL Level Voltage :  $0 \leq V_{IL} \leq 0.8$ ,  $2 \leq V_{IH} \leq V_{DD}$ ,  $0 \leq V_{OL} \leq 0.4$ ,  $2.4 \leq V_{OH} \leq V_{DD}$  (Volt)

**Analog Voltage:** 0.5~4.5V (option)

**Pin Map with JP-1 jumper selection.**

JP-1	C2H4-LD
1	N (Normal)
2	CAL1 (MCDL)
3	CAL2 (ACDL)

**0\_MCDL (2 minutes Manual Calibration)**

'0' ppm Manual Calibration can be done by locating jumper-cap on JP-1:pin2, another way is giving start command or low signal to CAL1-pin at least more than 2 minutes since the fresh air is fully balanced near sensor.

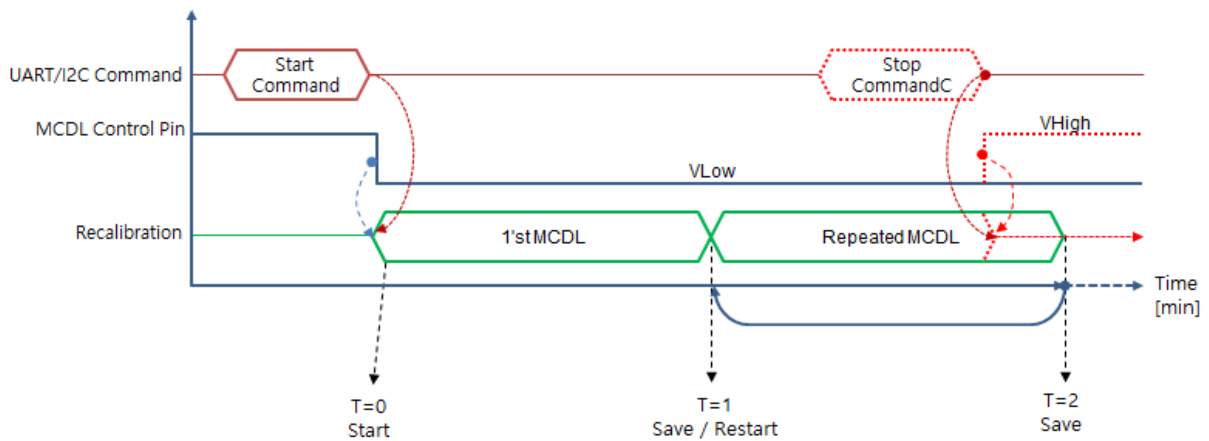

## 0\_ACDL (Periodic Automatic Calibration)

'0' ppm Periodic Automatic Calibration can be done by locating jumper-cap on JP-1:pin2, another way is giving start command or low signal to CAL2-pin. The sensor calibrate once in 1 day and every other day since then. '0'ppm Standard Gas can be used when the place doesn't face free air during the period.

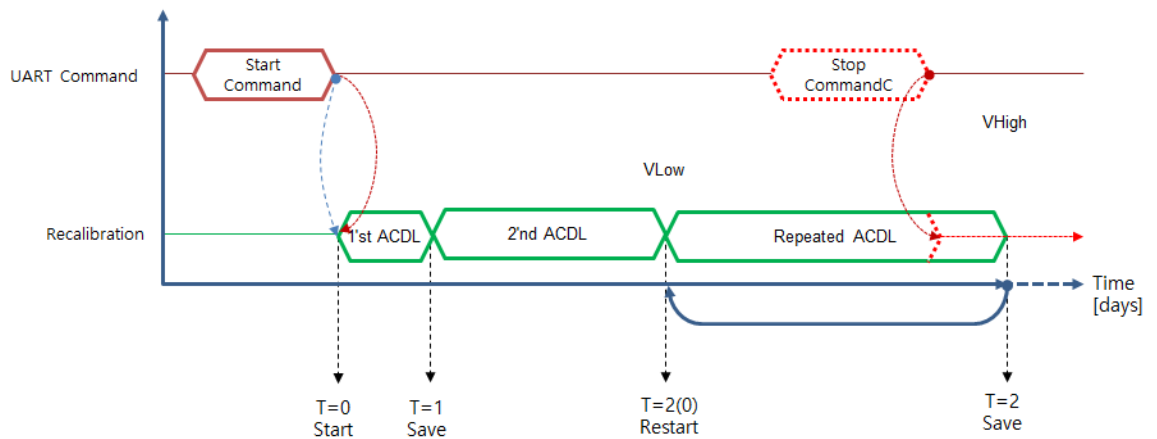

Method 1. UART Command Set; J12: pin-1 (UART-RX) and pin-2 (UART-TX) to Main-Board (J13: pin-5 and pin-6 are available as well.)

Method 2. I2C Command Set; J12: pin-3 (SCL) and pin-4 (SDA) to Main-Board. (J13: pin-8 and pin-9 are available as well.)

Method 3. Let Sensor install on Jig Board, **TRB-100ST (Test and Recalibration Board)** with ambient air-flow condition or with 0'ppm Standard Gas and execute by moving jumper following Manual on the website.

Method 4. Send string command set below to RXD-pin of Sensor on Emulation program.

**EK-100SL (Evaluation kit, with Emulation program 'ELTWSO')** is available

Method 5. CAL1 / CAL2-pin settings for 0\_MCDL / 0\_ACDL

CAL1 0_MCDL	CAL 2 0_ACDL	Function	Process
<b>Low</b>	High	H/W '0'ppm MCDL	Let C2H4-D3 sensor be located at ambient place where no Ethylene gas exist and wait 2 minute. '0'ppm Standard gas can be used when '0'ppm is not guaranteed.
High	<b>Low</b>	H/W '0' ppm ACDL	Automatic Calibration can be used where C2H4 meet the clear air more than 3 minutes per week.
High	High	Normal	Operate with Factory Calibrated or previously set status

- ※ 1. CAL-1pin and CAL-2pin shouldn't have 'Low' at the same time.
- 2. Be sure to escape MCDL fetch loop between 2 minutes and 4minutes to avoid inappropriate calibration.

**Cavity Dimensions (unit : mm)**



## Output Descriptions

### UART Descriptions

Data Format

SP	SP	SP	D2	D1	'%'	SP	'L'	'E'	'L'	CR	LF
SP x 3						Space: 0x20					
D2 ~ D1						2 byte C2H4 density string					
%						% : 0x25					
SP						Space: 0x20					
'LEL'						'LEL' string					
CR						Carriage return : 0x0D					
LF						Line feed : 0x0A					

Above 12byte consist by 2 byte hexadecimal digits, <SP>,<SP>,<SP>, D2, D1, 0x25, <SP>, 'L', 'E', 'L', <CR><LF> , where decimal '0' (corresponds to hexadecimal digit '0x30') is replaced by space (corresponds to hexadecimal digit '0x20'),

EX) 12% LEL (= 3,500 ppm) string is '0x20 0x20 0x20 0x31 0x32 0x25 0x20 0x4C 0x45 0x4C, 0x0D 0x0A',, of which display on the screen is ' \_\_12%\_LEL<CR><LF>'.

'ppm' display is Option on sale, which D6~D1 string display the C2H4 concentration of

D6	D5	D4	D3	D2	D1	SP	'p'	'p'	'm'	CR	LF
----	----	----	----	----	----	----	-----	-----	-----	----	----

EX) 3,500 ppm string is '0x20 0x20 0x33 0x35 0x30 0x30 0x20 0x70 0x70 0x6D 0x0D 0x0A', of which display on the screen is ' \_\_3500\_ppm<CR> <LF>'.

### I2C Communication (Only Slave Mode Operation)

Internal pull up resistor 10kΩ

Slave Address: 0x31, Slave Address Byte: Slave Address(0x31) 7 Bit + R/W 1 Bit

Bit7	Bit6	Bit5	Bit4	Bit3	Bit2	Bit1	Bit0
0	1	1	0	0	0	1	R/W Bit

R/W Bit : Read = 1/Write = 0

When reading the data, Slave Address Byte is 0x63, When writing the data, Slave Address Byte is 0x62.

### Block Diagram

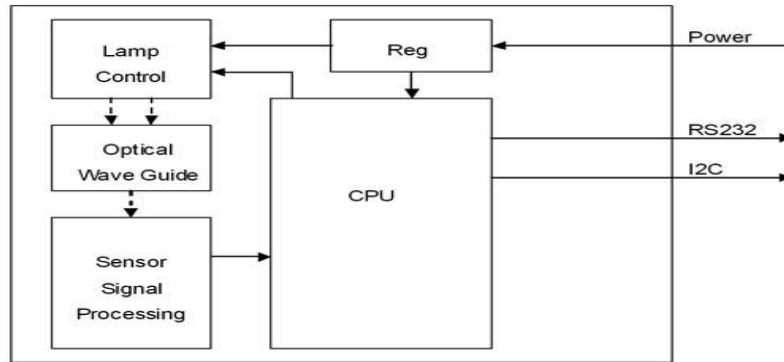

**Transmission Sequence in Master**

- 1) I2C Start Condition
  - 2) Write Command(Slave Address + R/W Bit(0) = 0x62) Transmission and Check Acknowledge
  - 3) Write Command(ASCII 'R' : 0x52) Transmission and Check Acknowledge
  - 4) I2C Stop Command
  - 5) I2C Start Command
  - 6) Read Command(Slave Address + R/W Bit(1) = 0x63) Transmission and Check Acknowledge
  - 7) Read 7 Byte Receiving Data from Module and Send Acknowledge
- (Delay at least 1ms for reading each byte)

Configuration	CO <sub>2</sub>	reserved	reserved	Reserved	reserved
1 Byte	2 Byte	0x00	0x00	0x00	0x00

0	0	0	0	1	0	0	0
---	---	---	---	---	---	---	---

In need of detail protocol specification and time sequence, 'I2C programming guide' could be provided by contacting Sales Rep.

**Analog Voltage Output Descriptions : Option**

Measured Voltage 0.5V~4.5V match proportionally to 0 ~ 100% LEL.

\* C<sub>2</sub>H<sub>4</sub> Measurement (ppm) =  $\frac{\text{Output Voltage} - 0.5}{(4.5 - 0.5) \text{ Voltage}} \times 100\% \text{ LEL}$ .

EX) if the Output Voltage is 2.5V in 0~100% LEL range,  
 $\text{C}_2\text{H}_4 (\% \text{ LEL}) = \frac{(2.5 - 0.5) \text{ V}}{(4.5 - 0.5) \text{ V}} \times 100\% \text{ LEL}$   
 $= 0.5 \times 100\% \text{ LEL} = 50\% \text{ LEL}$

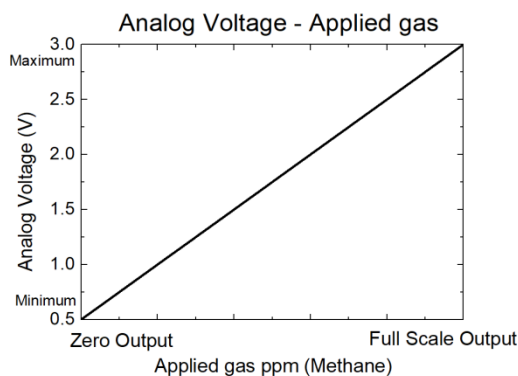

6. Automatic Calibration (ACDL) could save management cost when the concentration is 50ppm or lower.

**Sensitivity by other CxHx Gas shows incomparably low.**

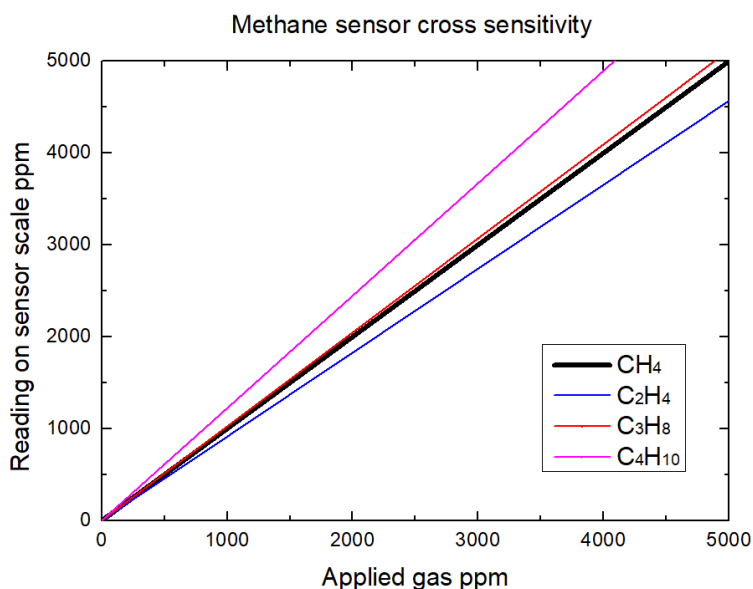

※Caution

1. Please use only 'PCB' of sensor to avoid the physical shock on sensor without holding Gold-Colored-Cavity directly. Rough handling or Transportation could result in inaccurate reading.. But, 0\_MCDL with CAL1 or 0\_ACDL with CAL2 are available to correct the sensor to normal status.
2. Proper ESD protection during handling is important to avoid electrostatic defect occurrence like motors and the storage of sensor should be insulated as well.
3. Sensor location should be protected from Vibration as far as possible, which could effect the sensor location
4. Sensor location should be a bit higher 1.5~2m because Ethylene gas has low specific gravity than air.
5. Manual Calibration (MCDL) is recommended when restart Sensor after long period storage or

effected by physical shock or drop. Please make sure to calibrate on operating environment when use higher or lower temperature or humidity than normal.

6. When MCDL was finished, please make sure to let the jumper-cap of JP-1 return to original location like ACDL or None.

7. Automatic Calibration (ACDL) could save management cost when the concentration is 50ppm or lower.

---

ELT SENSOR Corp.

Chunui Technopark 101-909) 36, Bucheon-ro 198beon-gil, Wonmi-gu,  
Bucheon-si, Gyeonggi-do, 420-857, Korea  
Phone. +82-32-719-8055, <http://www.eltensor.co.kr>

Subject to change without notice. Printed in KOREA  
2014 ELT Sensor Corp. All rights reserved.  
2017. FEB