

## General

Ver. 1.2

C2H4-LD-3V is NDIR type dual channel ethylene sensor module. Its consistent stability and Temperature Effect Resistance are much favored on monitoring ethylene gas concentration change during fruit storing and transportation due to its consistent accuracy through the life cycle.. C2H4-LF-3V could save buy using 3.3Voltage input or so .

---

# ELT Sensor Data Sheet for C2H4-LD-3V



## Features

- Non-Dispersive Infrared (NDIR) Dual Channel Technology to measure C2H4 levels.
  - Excellent compensation of Temperature Effect on C2H4 concentration.
  - Output : TTL-UART, I2C, ALARM,  
PWM or Analog Voltage is optional.
  - Easy Calibration with Non-Periodic Manual Calibration (0\_MCDL : CAL1) and Periodic Automatic Calibration (0\_ACDL : CAL2).
- 
- Size : 40mmx38mmx18.5mm
  - Weight : 20 grams

## Specifications

### Applications

C2H4-LD-3V sensor modules monitor and control ripeness of plants growing, storing and transport of bananas or other fruit, etc.

### General Performance

**Operating Temperature :** -20 ~ 50°C

**Operating Humidity :** 0 ~ 95% RH (Non-condensing), 'G : 0 ~ 99% RH (Non-condensing)<sup>(1)</sup>

**Storage Temperature :** -30°C ~70°C

### Measurement

**Sensing Method :** NDIR (Non-dispersive Infrared)

**Measurement Range :** Option: 0~2,000ppm (0~27,000 ppm is option)

**Accuracy :** ±3% of F.S. <sup>(1),(2),(3),(4)</sup>

**Output unit:** ppm

**Resolution:** 50ppm

**Lowest Detection Limit:** 100ppm @25°C

**Step Response Time (90%, 1/e) :** 30 seconds / 20 seconds

**Sampling Interval:** 3 seconds

**Warming-up Time :** < 6 seconds (for Detection), 2 minutes (for Accuracy)

### Electrical Data

**Power Input :** 5V ± 5% (5)

**Current Consumption :** Normal mode : 14mA, Peak : 270mA

### Product Derivatives and Relative Functions

Products	Feature	5V Option
C2H4-LDG-3V	Enable sensor to operate in very humid environment up to 99 %RH humidity, protecting PCB from rustiness.	C2H4-LDG
C2H4-LF-3V	Flow-thru type of C2H4-LD-3V, open two holes on side and disable the white colored filter on the top of Gold Cavity.	C2H4-LFG
C2H4-LFG-3V	Enable sensor to operate in very humid environment up to 99 %RH humidity, protecting PCB from rustiness.	C2H4-LFG

C2H4-LD-3V has various output TTL-UART, I2C while as Analog voltage is selectable as option.

### Pin Map with J11&J12 Connectors

- (1) C2H4-LD-3V-G: 0 ~ 99% RH (Non-condensing) for Industrial Application of Ethylene gas.
- (2) 2% should be added for absolute measurements for uncertainty of calibration gas mixture unless '0' ppm or '0'ppm standard gas calibration is done.
- (3) Air pressure is assumed as 101.3 kPa.
- (4) If sensor is affected by the shock, may need field calibration before installation.
- (5) DC Supply should be regulated without ripple < 100mV, low noise power source is needed for best accuracy.

J-11	Description	
1/3	V <sub>DD</sub> (+3.3VDC)	
2/4	GND	

J-12	C2H4-LD-3V	C2H4-LD-3V (Analog Voltage Option)
1	TTL RXD (← CPU of Master Board )	
2	TTL TXD (→ CPU of Master Board)	
3	I2C SCL	
4	I2C SDA	
5	GND	
6	Reserved	Analog Voltage Output (0.5~3V)
7	CAL2-pin : 0_ACDL (for every 7 days ACDL with periodic CO2-'0'ppm circumstance)	
8	Reserved	
9	CAL1-pin : 0_MCDL (for 2 minutes MCDL with C2H4-'0'ppm- N2-based-gas or Fresh Air)	
10	Reset (Low Active)	

**UART** 38,400BPS, 8bit, No parity, 1 stop bit  
 9,600 or 19,200 BPS can selectable through command sets or EK-100SL.

**I2C** Slave mode only, Internal pull up resistor 10kΩ  
 TTL Level Voltage :  $0 \leq V_{IL} \leq 0.4$ ,  $2 \leq V_{IH} \leq V_{DD}$ ,  $0 \leq V_{OL} \leq 0.4$ ,  $2.4 \leq V_{OH} \leq V_{DD}$  (Volt)

**Analog Voltage:** 0.5~4.5V (option)

### Pin Map with JP-1 jumper selection.

JP-1	C2H4-LD-3V
1	N (Normal)
2	CAL1 (MCDL)
3	CAL2 (ACDL)

### 0\_MCDL (2 minutes Manual Calibration)

'0' ppm Manual Calibration can be done by locating jumper-cap on JP-1:pin2, another way is giving start command or low signal to CAL1-pin at least more than 2 minutes since the fresh air is fully balanced near sensor.

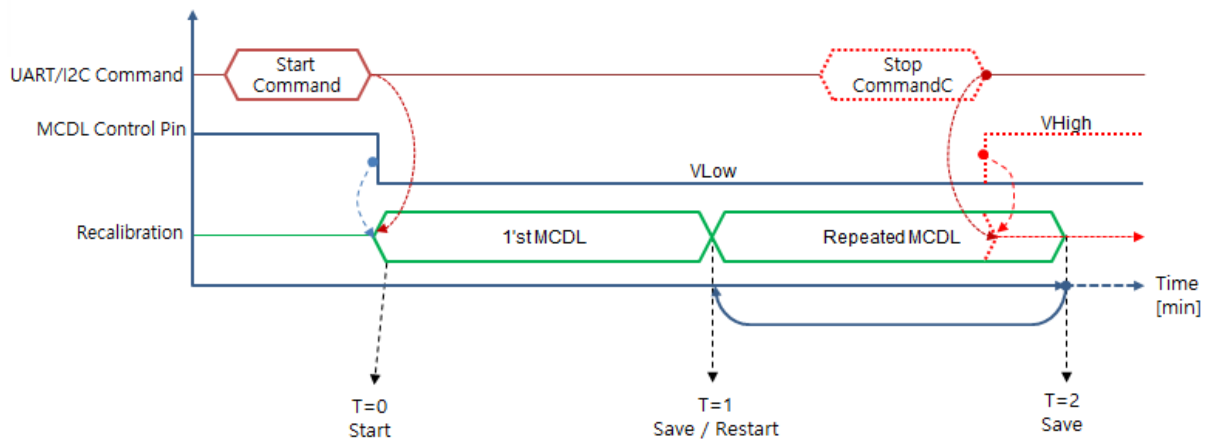

## 0\_ACDL (Periodic Automatic Calibration)

'0' ppm Periodic Automatic Calibration can be done by locating jumper-cap on JP-1:pin2, another way is giving start command or low signal to CAL2-pin. The sensor calibrate once in 1 day and every other day since then. '0'ppm Standard Gas can be used when the place doesn't face free air during the period.

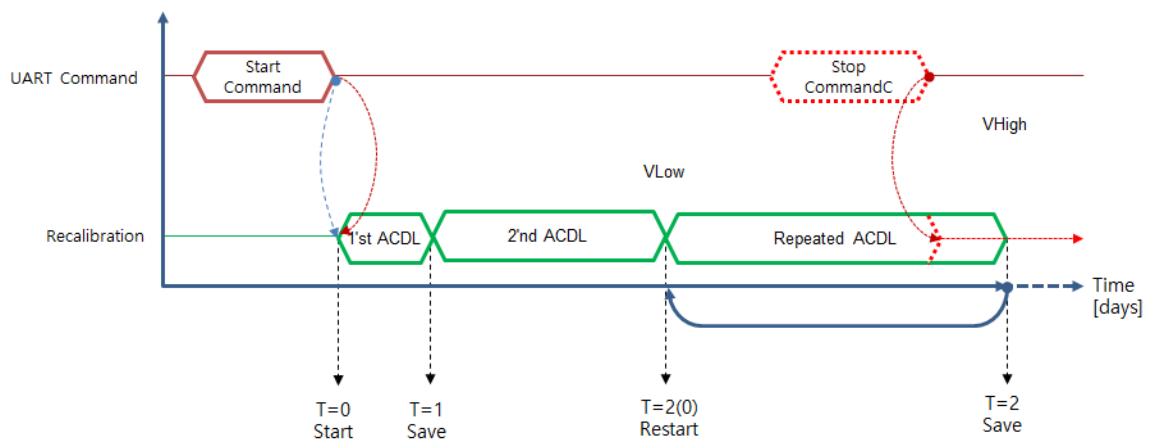

Method 1. UART Command Set; J12: pin-1 (UART-RX) and pin-2 (UART-TX) to Main-Board (J13: pin-5 and pin-6 are available as well.)

Method 2. I2C Command Set; J12: pin-3 (SCL) and pin-4 (SDA) to Main-Board. (J13: pin-8 and pin-9 are available as well.)

Method 3. Let Sensor install on Jig Board, **TRB-100ST (Test and Recalibration Board)** with ambient air-flow condition or with 0'ppm Standard Gas and execute by moving jumper following Manual on the website.

Method 4. Send string command set below to RXD-pin of Sensor on Emulation program.

**EK-100SL (Evaluation kit, with Emulation program 'ELTWSO')** is available

Method 5. CAL1 / CAL2-pin settings for 0\_MCDL / 0\_ACDL

CAL1 0_MCDL	CAL 2 0_ACDL	Function	Process
<b>Low</b>	High	H/W '0'ppm MCDL	Let C2H4-D3 sensor be located at ambient place where no Ethylene gas exist and wait 2 minute. '0'ppm Standard gas can be used when '0'ppm is not guaranteed.
High	<b>Low</b>	H/W '0' ppm ACDL	Automatic Calibration can be used where C2H4 meet the clear air more than 3 minutes per week.
High	High	Normal	Operate with Factory Calibrated or previously set status

- ※ 1. CAL-1pin and CAL-2pin shouldn't have 'Low' at the same time.
- 2. Be sure to escape MCDL fetch loop between 2 minutes and 4minutes to avoid inappropriate calibration.



## Output Descriptions

### UART Descriptions

#### Data Format

Above 12byte consist by 2 byte hexadecimal digits, <SP>,<SP>,<SP>, D2, D1, 0x25, <SP>, 'p', 'p', 'm', <CR><LF> , where decimal '0' (corresponds to hexadecimal digit '0x30') is replaced by space (corresponds to hexadecimal digit '0x20'),

EX) D6~D1 string display the C2H4-LF-3V concentration of

D6	D5	D4	D3	D2	D1	SP	'p'	'p'	'm'	CR	LF
SP x 3						Space: 0x20					
D2 ~ D1						2 byte C2H4 density string					
%						% : 0x25					
SP						Space: 0x20					
'ppm'						' ppm' string					
CR						Carriage return : 0x0D					
LF						Line feed : 0x0A					

EX) 3,500 ppm string is '0x20 0x20 0x33 0x35 0x30 0x30 0x20 0x70 0x70 0x6D 0x0D 0x0A', of which display on the screen is '\_ \_3500\_ppm<CR> <LF>'.

### I2C Communication (Only Slave Mode Operation)

Internal pull up resistor 10kΩ

Slave Address: 0x31, Slave Address Byte: Slave Address(0x31) 7 Bit + R/W 1 Bit

Bit7	Bit6	Bit5	Bit4	Bit3	Bit2	Bit1	Bit0
0	1	1	0	0	0	1	R/W Bit

R/W Bit : Read = 1/Write = 0

When reading the data, Slave Address Byte is 0x63, When writing the data, Slave Address Byte is 0x62.

#### Block Diagram

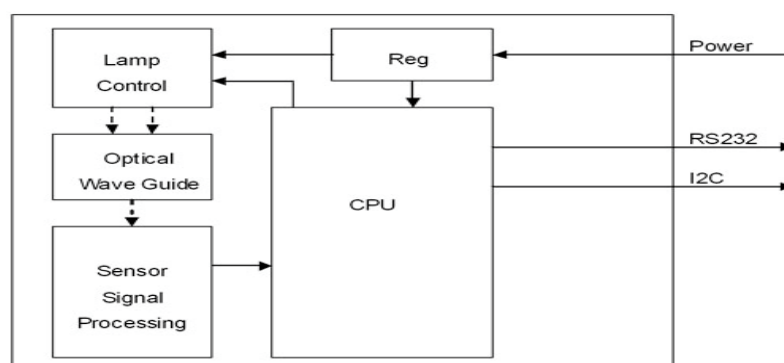

**Transmission Sequence in Master**

- 1) I2C Start Condition
- 2) Write Command(Slave Address + R/W Bit(0) = 0x62) Transmission and Check Acknowledge
- 3) Write Command(ASCII 'R' : 0x52) Transmission and Check Acknowledge
- 4) I2C Stop Command
- 5) I2C Start Command
- 6) Read Command(Slave Address + R/W Bit(1) = 0x63) Transmission and Check Acknowledge
- 7) Read 7 Byte Receiving Data from Module and Send Acknowledge  
(Delay at least 1ms for reading each byte)

Configuration	CO <sub>2</sub>	reserved	reserved	Reserved	reserved
1 Byte	2 Byte	0x00	0x00	0x00	0x00

0	0	0	0	1	0	0	0
---	---	---	---	---	---	---	---

In need of detail protocol specification and time sequence, 'I2C programming guide' could be provided by contacting Sales Rep.

**Analog Voltage Output Descriptions : Option**

Measured Voltage 0.5V~3V match proportionally to 0 ~ 2,000ppm.

\* C2H4 Measurement (ppm) =  $\frac{\text{Output Voltage} - 0.5}{3 - 0.5} \times 2,000\text{ppm}$ .

EX) if the Output Voltage is 2.5V in 0~2,000ppm range,  

$$\text{C2H4 (ppm)} = \frac{2.5 - 0.5}{3 - 0.5} \times 2,000\text{ppm}$$

$$= 0.8 \times 2,000\text{ppm} = 1,600\text{ppm}$$

※Caution

1. Please use only 'PCB' of sensor to avoid the physical shock on sensor without holding Gold-Colored-Cavity directly. Rough handling or Transportation could result in inaccurate reading..  
But, 0\_MCDL with CAL1 or 0\_ACDL with CAL2 are available to correct the sensor to normal status.
2. Proper ESD protection during handling is important to avoid electrostatic defect occurrence like motors and the storage of sensor should be insulated as well.
3. Sensor location should be protected from Vibration as far as possible, which could effect the sensor location

4. Sensor location should be a bit higher 1.5~2m because Ethylene gas has low specific gravity than air.
5. Manual Calibration (MCDL) is recommended when restart Sensor after long period storage or effected by physical shock or drop. Please make sure to calibrate on operating environment when use higher or lower temperature or humidity than normal.
6. When MCDL was finished, please make sure to let the jumper-cap of JP-1 return to original location like ACDL or None.
7. Automatic Calibration (ACDL) could save management cost when the concentration is 50ppm or lower.

---

ELT SENSOR Corp.

Chunui Technopark 101-909) 36, Bucheon-ro 198beon-gil, Wonmi-gu,  
Bucheon-si, Gyeonggi-do, 420-857, Korea  
Phone. +82-32-719-8055, <http://www.eltensor.co.kr>

Subject to change without notice. Printed in KOREA  
2017 ELT Sensor Corp. All rights reserved.